

# SAFA SERIES FIRE & SMOKE DAMPER ACTUATOR

2 Point Spring Return Control  
3 Nm

## SAFA...03S (T) SERIES

SAFA series Spring Return damper actuators are designed specifically for fire and smoke application. During normal operation, the actuator motorized the damper. In the event of fire emergency, the actuator springs back to its original position when there is power outage or trip by thermal sensor.



## PRODUCT FEATURE

- Torque 3 Nm
- Damper size 0.6 m<sup>2</sup>
- Power supply AC/DC 24V and AC 230 V
- Shaft dimensions - Form fit 12 mm square
- Adapter supplied for Form fit 8 or 10 mm square
- Selectable direction of rotation
- Actuator with 1 m cable connection
- 2 Fixed auxiliary switches (SPDT)
- Manual Over-ride by crank handle when required
- Thermal sensor option available
- Anti rotation bracelet provided

## MODEL SELECTION TABLE

MODEL / TYPE	TORQUE	POWER SUPPLY	RUNNING TIME	AUXILIARY SWITCHES	THERMAL SENSOR
SAFA 1-03S	3 Nm	AC/DC 24 V ± 10%	25...35 sec (Spring Back <12 sec)	2 x SPDT (Fixed)	-
SAFA 1-03ST	3 Nm	AC/DC 24 V ± 10%	25...35 sec (Spring Back <12 sec)	2 x SPDT (Fixed)	Yes
SAFA 2-03S	3 Nm	AC 230 V ± 10%	25...35 sec (Spring Back <12 sec)	2 x SPDT (Fixed)	-
SAFA 2-03ST	3 Nm	AC 230 V ± 10%	25...35 sec (Spring Back <12 sec)	2 x SPDT (Fixed)	Yes

## DIMENSION (mm)

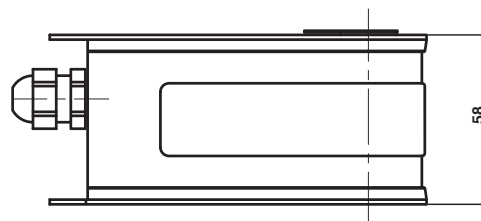
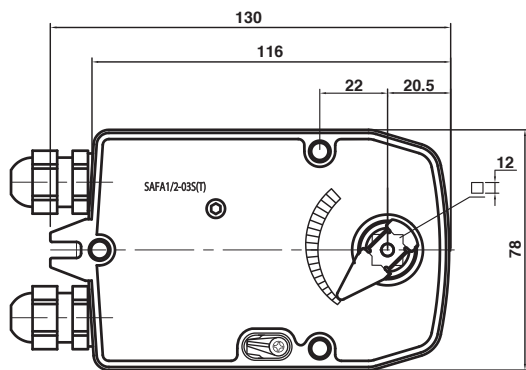

## TECHNICAL SPECIFICATION

MODEL NUMBER	SAFA 1-03S (T)	SAFA 2-03S (T)
TORQUE	3 Nm	3 Nm
DAMPER SIZE	0.6 m <sup>2</sup>	0.6 m <sup>2</sup>
SHAFT DIMENSION	Form fit 12 mm square	Form fit 12 mm square
POWER SUPPLY	AC/DC 24 V ± 10%	AC 230 V ± 10%
FREQUENCY	50...60 Hz	50...60 Hz
CONTROL SIGNAL	2 point control	2 point control
POWER CONSUMPTION		
● OPERATING	7.0 W	7.0 W
● END POSITION	2.5 W	2.5 W
FOR WIRE SIZING	10.0 VA	10.0 VA
ELECTRICAL CONNECTION	1 m Cable	1 m Cable
AUXILIARY SWITCHES RATING	3 (1.5) A, AC 250 V	3 (1.5) A, AC 250 V
PROTECTION CLASS	Class III ⚡	Class II ⚡
ANGLE OF ROTATION	90° (95° mechanical)	90° (95° mechanical)
THERMAL TEMPERATURE TRIP	> 72°C	> 72°C
WEIGHT	1.8 Kg	1.9 Kg
LIFE CYCLE	60,000 Rotation	60,000 Rotation
SOUND LEVEL	40 dB	40 dB
IP PROTECTION	IP54	IP54
OPERATING TEMPERATURE	-20°...50° as per IEC 721-3-3	-20°...50° as per IEC 721-3-3
NON-OPERATING TEMPERATURE	-30°...+60° C / IEC 721-3-2	-30°...+60° C / IEC 721-3-2
AMBIENT HUMIDITY	5%...95% rH non condensing / EN	5%...95% rH non condensing / EN
MAINTENANCE	Maintenance Free	Maintenance Free
MODE OF OPERATION	Type I / EN 60730-1	Type I / EN 60730-1
EMC	CE, UL 873 & ISO 9000 EN / EEC	CE, UL 873 & ISO 9000 EN / EEC

# SAFA SERIES FIRE & SMOKE DAMPER ACTUATOR

2 Point Spring Return Control

3 Nm

## WIRING DIAGRAM SAFA...03S (T) POWER SUPPLY AC/DC 24 V / AC 230V

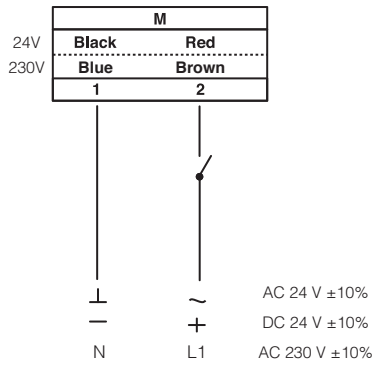

## DIRECTION OF ROTATION SAFA...03S (T)

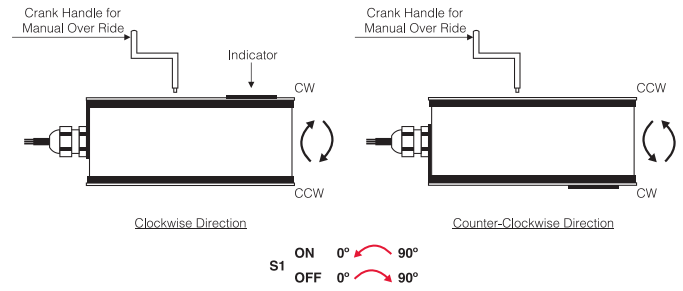

## WIRING DIAGRAM SAFA...03S (T) AUXILIARY SWITCHES

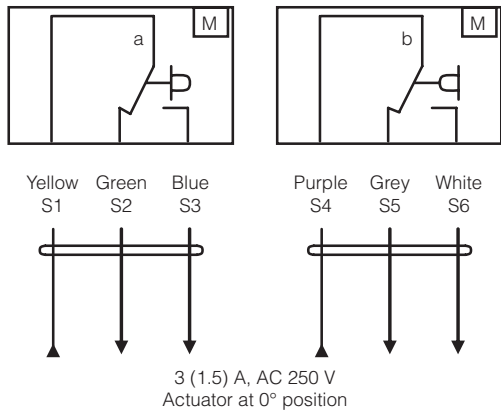

## AUXILIARY SWITCHES SAFA...03S (T)

Auxiliary are fixed at 5° for switch (a) and 85° for switch (b)  
Auxiliary switches are non adjustable.

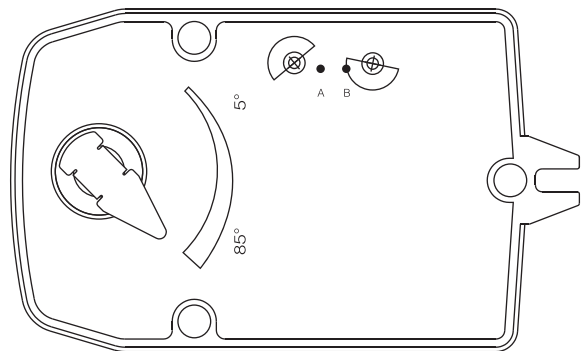

## THERMAL SENSOR NTS72

Thermal Sensor NTS 72 consist of both Ambient (TS1) and Duct sensor (TS2).

- TS1 will trip open when the ambient temperature rise above 72°.
- TS2 will trip open when the duct temperature rise above 72°.

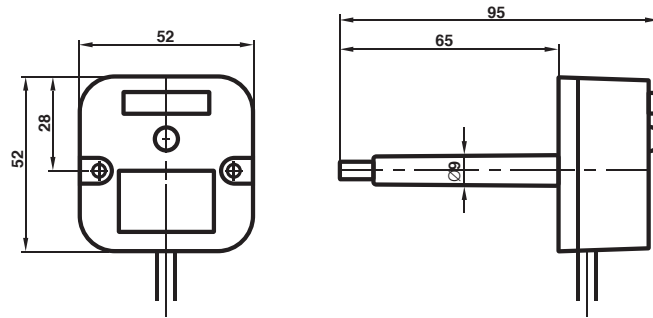

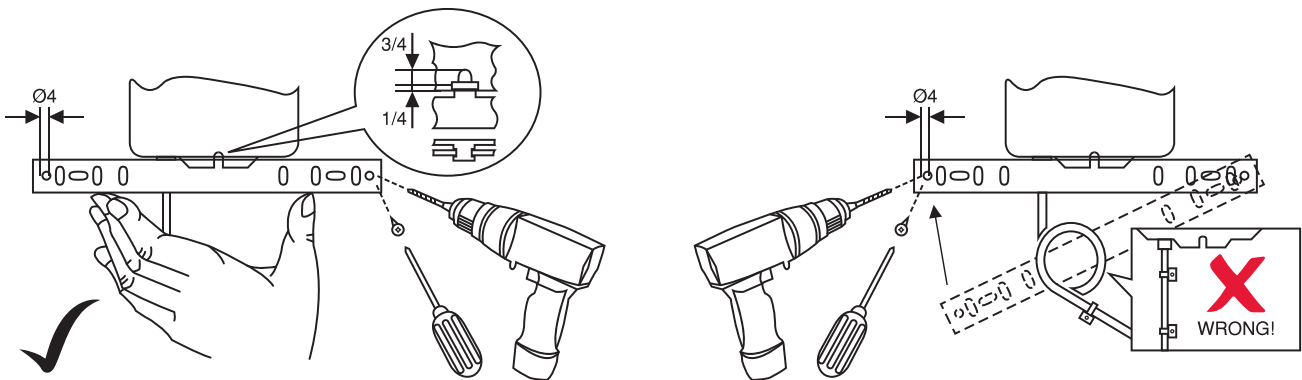

## INSTALLATION / MOUNTING INSTRUCTION



## IMPORTANT REMARK

For special requirement, consult your local Nenutec's representative.

  This actuator includes electrical and electronic components and may not be disposed as household garbage. Please consider the local valid legislation.

 AC / DC 24 V: Connect via safety isolating transformer.  
AC 230 V: To isolate from the main power supply, the system must incorporate a device which disconnects the phase conductor (with at least a 3mm contact gap.)

The performance specifications are nominal and conform to acceptable industry standards. Nenutec shall not be liable for damages resulting from misapplication or misuse of its products.