

NTS-900 SERIES

NTC TEMPERATURE SENSOR

NTS-900

NENUTEC is proud to offer the NTS 900 passive sensor. They are designed for use with NTC 600 and NTC 650 series Temperature controller for a variety of heating and cooling applications controlled by water valves and damper actuator.



TECHNICAL SPECIFICATION

MODEL NUMBER	NTS-900
TEMPERATURE RANGE	-40 to 100°C
TEMP SENSOR ELEMENT	NTC Thermistor 10K Ω at 25°C
ACCURACY	$\pm 1^\circ\text{C}$
BODY MATERIAL	Self-extinguishing, Molded ABS
IP PROTECTION	IP30
AMBIENT TEMPERATURE	-20°...50° as per IEC721-3-3
AMBIENT HUMIDITY	5...95% rH (non Condensing)
INVENTORY TEMPERATURE	+70°C as per IEC 721-3-2
CERTIFICATION	CE and ISO 9000 (EN...requirements)

DIMENSION (mm)

PIPE TYPE

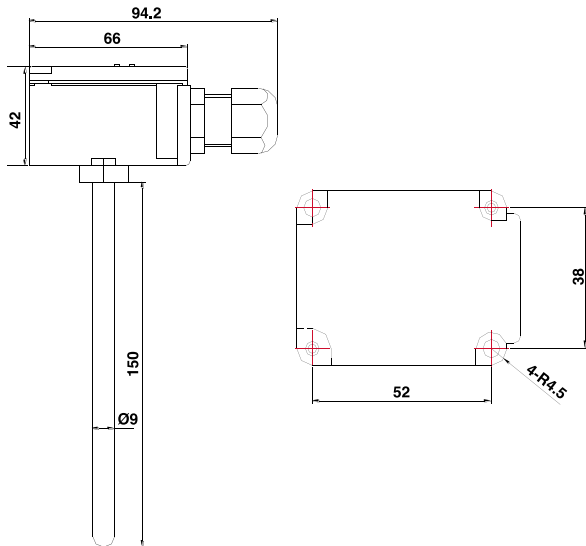

DUCT TYPE

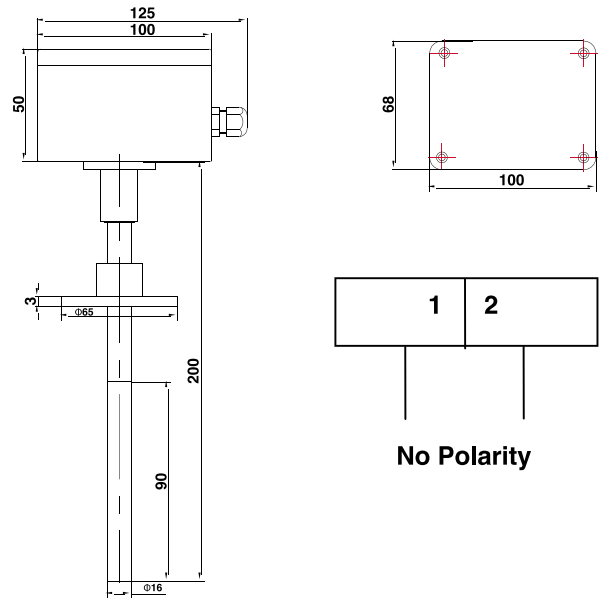

The performance specifications are nominal and conform to acceptable industry standards. NENUTEC shall not be liable for damages resulting from misapplication or misuse of its products

IMPORTANT REMARK

For special requirement, consult your local Nenuotec's representative.



This actuator includes electrical and electronic components and may not be disposed as household garbage. Please consider the local valid legislation.

AC / DC 24 V: Connect via safety isolating transformer.
AC 230 V: To isolate from the main power supply, the system must incorporate a device which disconnects the phase conductor (with at least a 3mm contact gap.)

The performance specifications are nominal and conform to acceptable industry standards. Nenuotec shall not be liable for damages resulting from misapplication or misuse of its products.